

Dimensions Milk Cooling Tanks DF953/95, 1 600-12 000 litres

All dimensions are according to drawings; small deviations in the acutal dimensions might occur.

Milk cooling tanks DF95,
1 600-12 000 litres

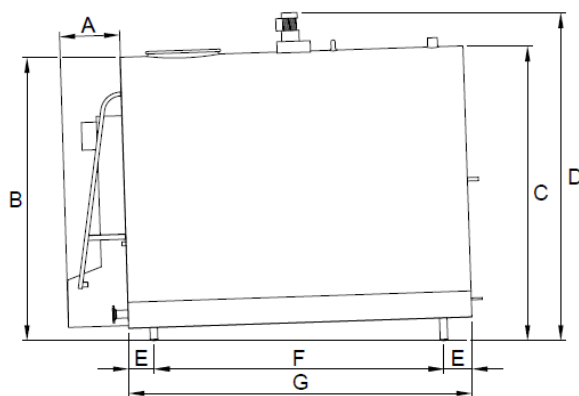
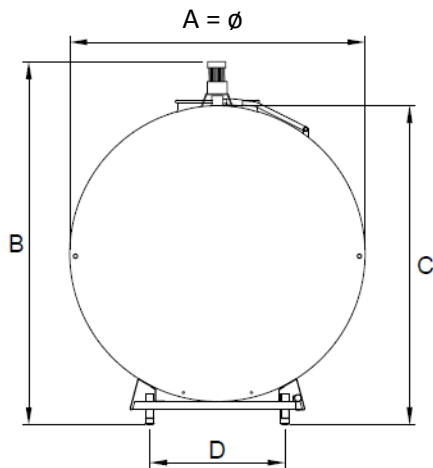

Volume (l)	A = ϕ (mm)	B (mm)	C (mm)	D (mm)	Weight (kg)
1 600	1 350	1 735	1 385	635	330
2 000	1 350	1 735	1 385	635	380
2 000	1 500	1 890	1 540	776	380
2 500	1 350	1 735	1 385	635	485
2 500	1 500	1 890	1 540	776	485
3 200	1 500	1 890	1 540	776	575
3 200	1 700	2 090	1 740	776	575
4 000	1 500	1 890	1 540	776	655
4 000	1 700	2 090	1 740	776	655
5 000	1 700	2 090	1 740	776	700
5 000	1 900	2 285	1 935	991	700
6 000	1 700	2 090	1 740	776	900
6 000	1 900	2 285	1 935	991	900
7 000	1 900	2 285	1 935	991	940
7 000	2 100	2 490	2 140	991	940
8 000	1 900	2 285	1 935	991	1 120
8 000	2 100	2 490	2 140	991	1 120
9 000	2 100	2 490	2 140	991	1 250
10 000	2 100	2 490	2 140	991	1 360
12 000	2 100	2 490	2 140	991	1 530

Milk cooling tanks DF95,
1 600-5 000 litres

Volume (l)	ϕ (mm)	A (mm)	B (mm)	C (mm)	D (mm)	E (mm)	F (mm)	G (mm)	Legs (pc)	Ag. (pc)	Spr. h. (pc)
1 600	1 350	400	1 480	1 520	1 751	164	1 150	1 495	4	1	1
2 000	1 350	400	1 480	1 532	1 751	164	1 540	1 885	4	1	1
2 000	1 500	400	1 628	1 678	1 909	164	1 156	1 501	4	1	1
2 500	1 350	400	1 480	1 545	1 752	164	1 911	2 253	4	1	1
2 500	1 500	400	1 628	1 688	1 909	164	1 465	1 809	4	1	1
3 200	1 500	400	1 628	1 704	1 910	164	1 935	2 278	4	1	1
3 200	1 700	400	1 824	1 883	2 105	164	1 441	1 783	4	1	1
4 000	1 500	400	1 628	1 722	1 920	164	2 496	2 841	4	1	1
4 000	1 700	400	1 824	1 897	2 110	164	1 865	2 208	4	1	1
5 000	1 900	400	2 020	2 093	2 302	164	1 851	2 194	4	1	1

All information is supplied without liability, technical changes reserved.

Milk cooling tanks DF95, 5 000-12 000 litres

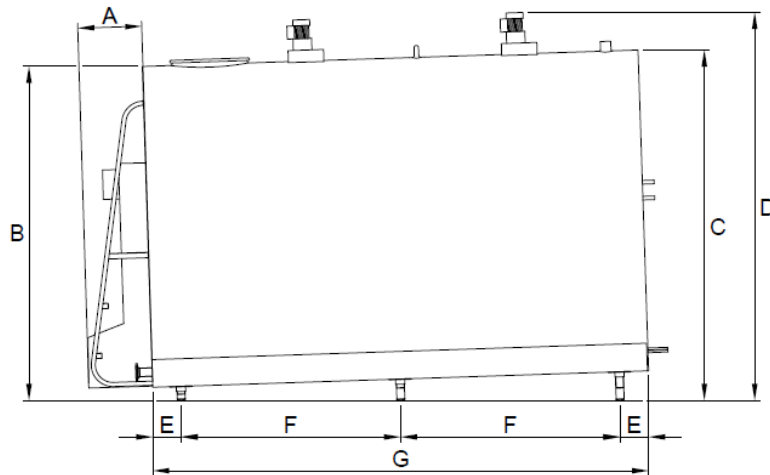

Volume (l)	Ø (mm)	A (mm)	B (mm)	C (mm)	D (mm)	E (mm)	F (mm)	G (mm)	Legs (pc)	Ag. (pc)	Spr. h. (pc)
5 000	1 700	400	1 824	1 914	2 127	173	1 195	2 738	6	1	1
6 000	1 700	400	1 824	1 932	2 152	173	1 458	3 263	6	2	1
6 000	1 900	400	2 020	2 106	2 305	173	1 131	2 609	6	1	1
7 000	1 900	400	2 020	2 119	2 344	173	1 328	3 002	6	2	1
7 000	2 100	412	2 222	2 304	2 506	173	1 066	2 469	6	1	1
8 000	1 900	400	2 020	2 134	2 351	173	1 549	3 444	6	2	1
8 000	2 100	412	2 222	2 315	2 540	173	1 231	2 799	6	2	1
9 000	2 100	412	2 222	2 326	2 552	173	1 403	3 143	6	2	1
10 000	2 100	412	2 222	2 338	2 555	173	1 576	3 488	6	2	1
12 000	2 100	412	2 222	2 360	2 566	173	1 910	4 156	6	2	1

Important information and recommendations

- Dimension B in the front view of the tank is the minimum height due to the lowest possible level of the adjustable legs.
- If needed to move the tank through a door into the milk room, the agitator/-s can be temporarily removed, which will reduce the height of the tank by approx. 250 mm.
- Tank weights are including the control unit, but excluding the cooling unit. For tanks with attached cooling unit (DF953), 100-215 kg should be added to the total weight (depending on type of cooling unit).
- Dimension D in the side view of the tank corresponds to the installed height at 1.9 degrees inclination.
- In order to get sufficient ventilation of the agitator motor and to make service possible, we recommend an empty space of at least 100 mm above the agitator motor.
- To make it possible to enter and exit the tank through the manhole, we recommend at least 600 mm empty space above the manhole.

All information is supplied without liability, technical changes reserved.

- Please be aware, that the dimension A in the side view (and thus the total length of the tank) will be effected if a robot kit (T-connection with APV valve/-s) is installed at the outlet. Add up to 400 mm, depending on the number of APV-valves (milk lines).

The minimum recommended length of the milk room is the sum of the following:

- Dimension A (plus robot connection/-s, if applicable)
- Dimension G
- Add 200 mm (if separated cooling unit), due to piping
- Add 670 mm (if attached cooling unit), due to the cooling unit
- Add at least 500 mm for service purpose