

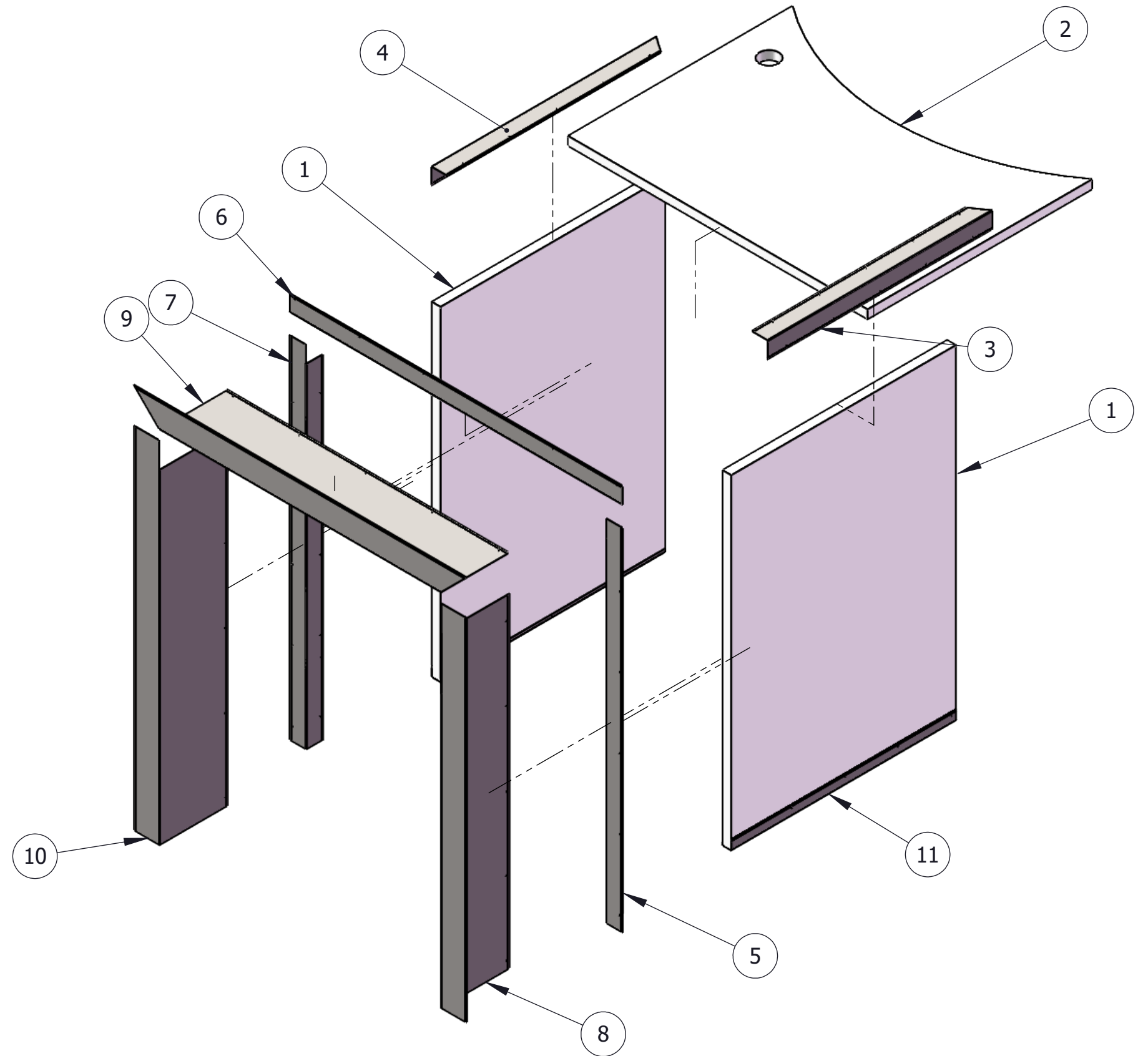

This document must not be copied without our written permission, and the contents thereof must not be imparted to a third party nor be used for any unauthorized purpose. Contention will be prosecuted. Wedholms AB

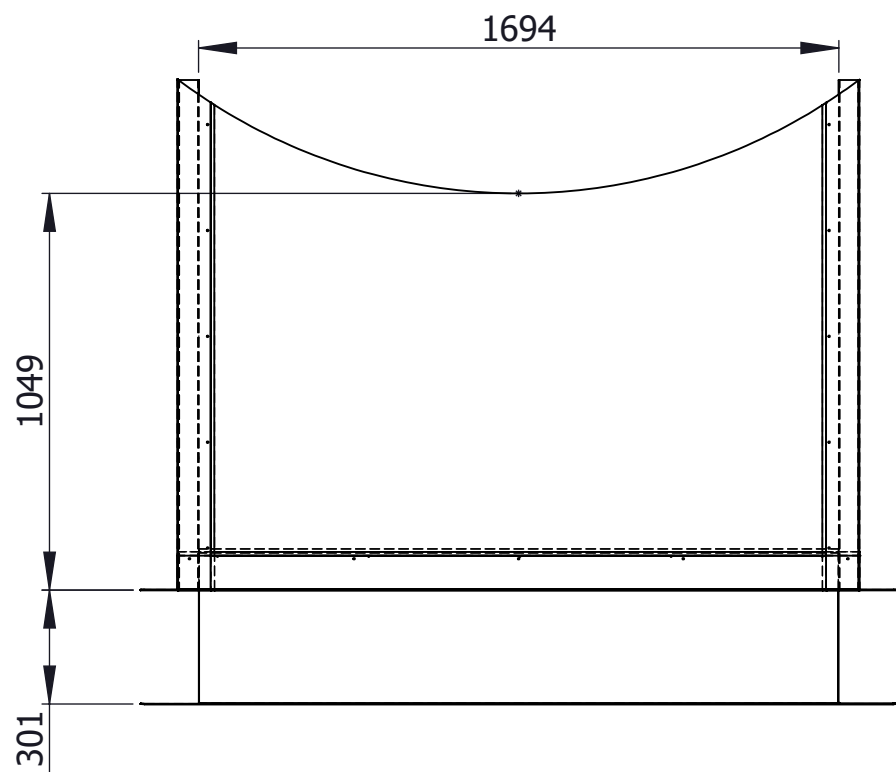
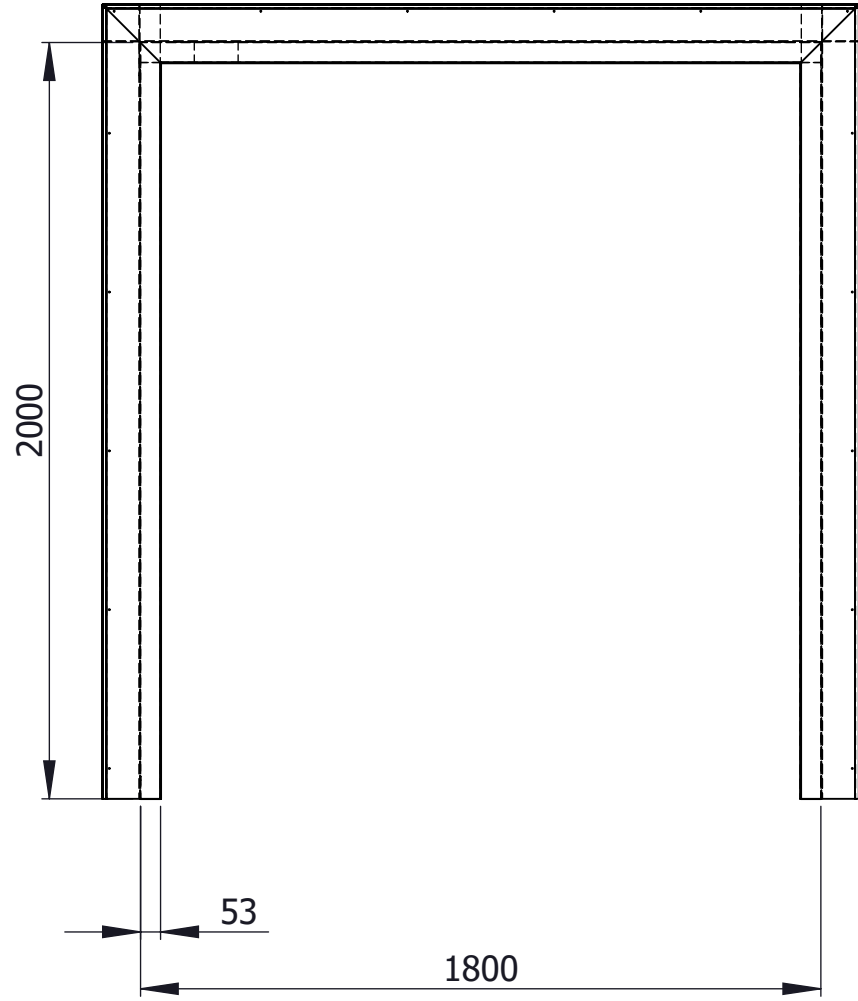

| | | | | | | | |
|-----------------------------------|--------------------|-------------------|-------------------------------------|---------------------------|---------------|---|--|
| Drawn by PR | Date 2020-08-21 | Approved by PR | ∇ indicates R_a in μm | | Scale 1:20 | Tolerances for untoleranced dimensions acc. to ISO 2768-1-m | |
| TANK Assembly of alcove | | | | | | Standard | |
| | | | | | | Weight 428893.06 | |
| Wedholms AB | | | Reference number | Drawing number 1000848 | | Revision E | |

This document must not be copied without our written permission, and the contents thereof must not be imparted to a third party nor be used for any unauthorized purpose. Contention will be prosecuted. Wedholms AB

| QTY. | POS | PART NUMBER | DESCRIPTION | DIMENTION | OPERATION |
|------|-----|-------------|----------------------------|-----------|-----------|
| 2 | 1 | 1001361 | Wall | | |
| 1 | 2 | 1000842 | Roof | | |
| 1 | 3 | 1000974 | Right cover profile | | |
| 1 | 4 | 1000851 | Left cover profile | | |
| 1 | 5 | 1000891 | Right wall cover profile | | |
| 1 | 6 | 1000892 | Roof cover profile | | |
| 1 | 7 | 1000893 | Left wall cover profile | | |
| 1 | 8 | 1000894 | Right inwall cover profile | | |
| 1 | 9 | 1000895 | Roof inner cover profile | | |
| 1 | 10 | 1000896 | Left inwall cover profile | | |
| 2 | 11 | 1000936 | Floor bracket | | |

| | | | | | | | |
|--|--------------------|-------------------|--|---|----------------------|--|--|
| Drawn by PR | Date 2020-08-21 | Approved by PR | $\sqrt{\quad}$ indicates R_a in μm |  | Scale 1:20 | Tolerances for untoleranced dimensions acc. to ISO 2768-1-m | |
| TANK Assembly of alcove | | | | | Comments | Standard | |
| | | | | | | Weight | |
|  Wedholms AB | | Reference number | Drawing number 1000848 | | Revision E | | |